

KY-019 1-Relais Modul Datenblatt

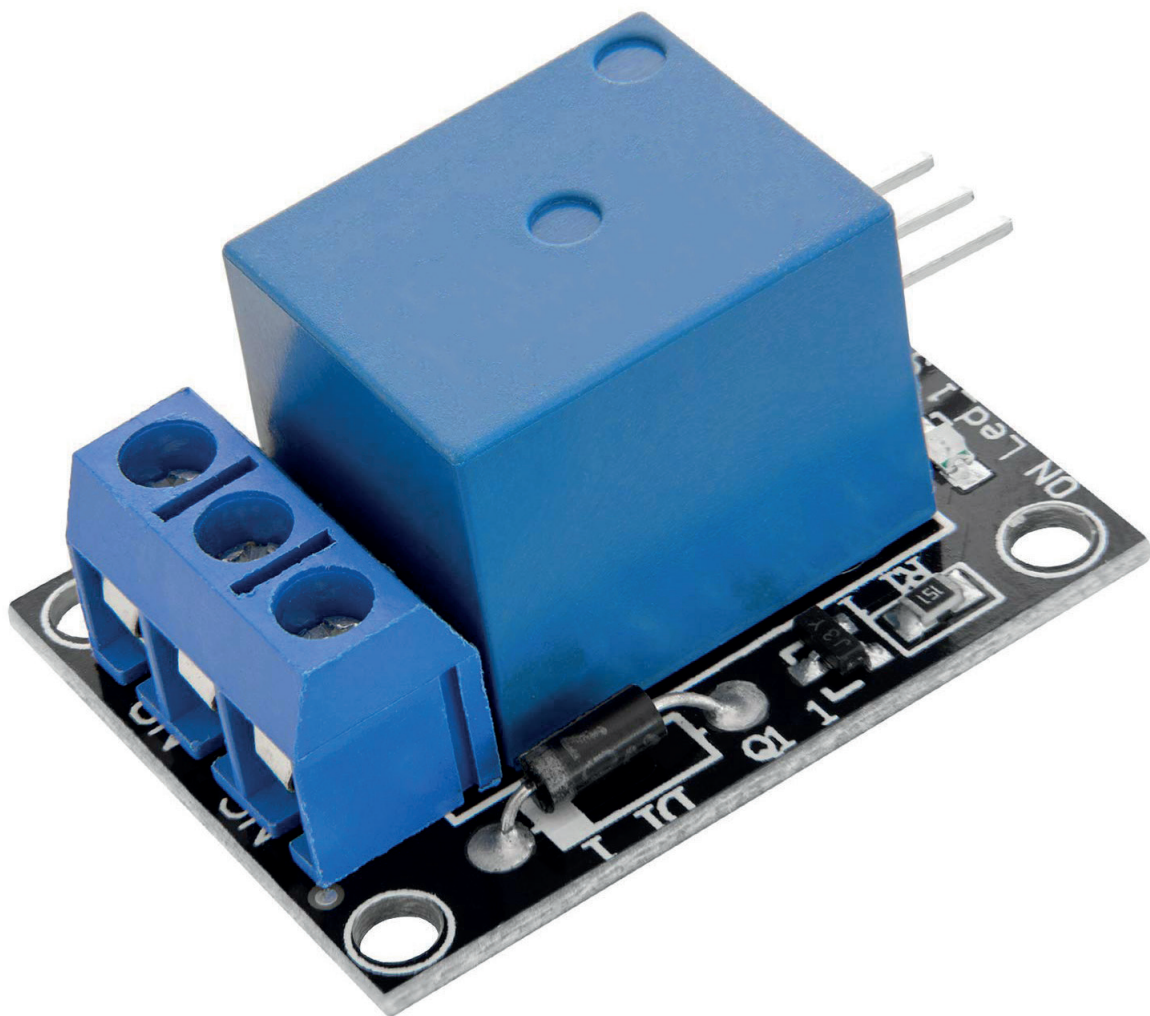

Content:

- [1. Brief Data](#)
- [2. Module Pinout](#)
- [3. Operating Principle](#)
- [4. Connection Diagram](#)

1. Brief Data

TTL Control Signal: 3.3V to 5V DC

Maximum AC: 5 A 50 V

Maximum DC: 5 A 30 V

Contact Type: Both: Normally Closed – NC, Normally Opened - NO

Dimensions: 27 mm x 34 mm x [1.1 in x 1.4 in]

2. Module Pinout

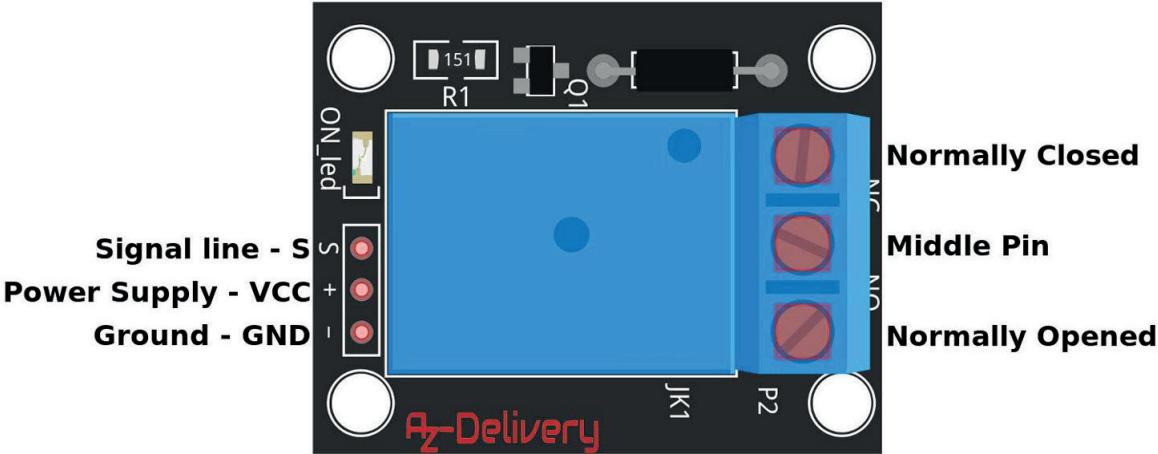

3. Operating Principle

There are two fixed contacts, a normally closed one and a normally open one.

When the coil is not energized, the normally open contact is the one that is off, while the normally closed one is the other that is on.

Supply voltage to the coil and some currents will pass through the coil thus generating the electromagnetic effect. So the armature overcomes the tension of the spring and is attracted to the core, thus closing the moving contact of the armature and the normally open (NO) contact or you may say releasing the former and the normally closed (NC) contact. After the coil is de-energized, the electromagnetic force disappears and the armature moves back to the original position, releasing the moving contact and normally closed contact. The closing and releasing of the contacts results in power on and off of the circuit.

4. Connection Diagram

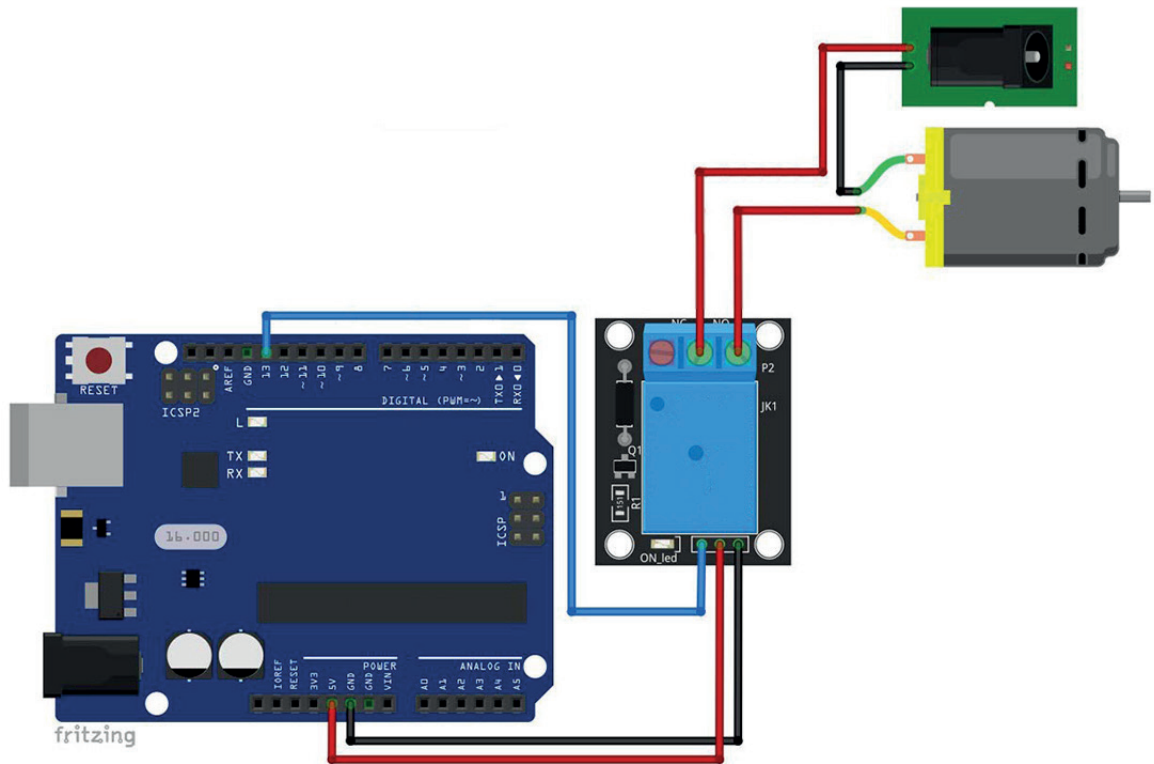

| Module Pin | Microcontroller Pin |
|------------|---------------------|
| S | D13 - Blue Wire |
| - (GND) | GND - Black Wire |
| + (VCC) | 5V - Red Wire |

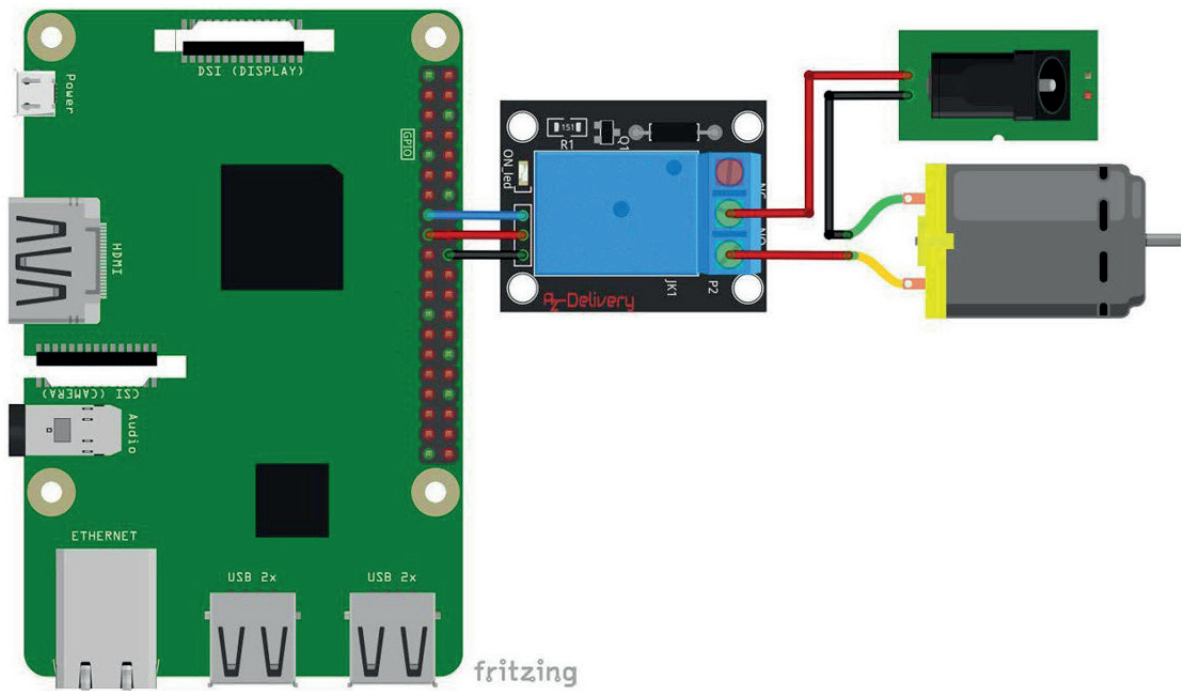

| Module Pin | Microcontroller Pin |
|------------|-----------------------------|
| S | GPIO23 - Blue Wire (Pin 16) |
| - (GND) | GND - Black Wire (Pin 20) |
| + (VCC) | 3V3 - Red Wire (Pin 17) |



SAFETY WARNING!

When doing projects that are connected to mains voltage, misuse may lead to serious electrical shock!

For the sake of your own safety, be 100% sure what you are doing! Otherwise, ask someone who knows!

According to Current regulations, working with mains voltage is reserved for qualified electricians only!

AZ-Delivery

Ihr Experte für Mikroelektronik!

If you are looking for the high quality products for Arduino and Raspberry Pi, AZ-Delivery Vertriebs GmbH is the right company to get them from. You will be provided with numerous application examples, full installation guides, eBooks, libraries and assistance from our technical experts.